



Features

- 3G module for real-time video streaming and vehicle position tracking
- Off-site cloud storage for video security and redundancy
- Records video simultaneously with audio, G-sensor and GPS data on a SD card
- Immediate access to recorded video – no waiting for DVR upload
- View multiple vehicles from a single login
- Simple web browser access to live and recorded video
- Local video management software
- 4 CH DVR – attach up to 4 analog cameras
- Video output for live view, playback to a local monitor
- H.264 compression format
- Single channel microphone
- 1 minute continuous video clips
- Time and date stamped on video recording

Fully-integrated Cloud-Enabled In-Vehicle Surveillance System

IvedaOnBoard

Inter-Cloud Video Management Platform

VEMO from Iveda Solutions® is an in-vehicle video surveillance system enabled for IvedaOnBoard. IvedaOnBoard is our mobile streaming video hosting service. Live and recorded video from vehicles are hosted in the cloud and centrally managed.

Videos can be viewed in one dashboard, including a map-based user interface for tracking current location of vehicles using VEMO's GPS. VEMO and IvedaOnBoard are the first fully integrated in-vehicle surveillance system streaming live to the cloud.

Applications



Law Enforcement

Protect Life, Support Officers, Reduce Response Time



School Bus

Stop Bullying, Protect Students, Stop Graffiti, Prevent Liability



Commercial Transportation

Monitor Assets and Improve Operations, Provide Driver Safety, Reduce Cargo Theft and Damage



Emergency Response Vehicles

Improve Safety, Save Lives, Get Critical Information as Events Unfold

Sentir

Iveda Solutions' many hosting services, including IvedaOnBoard, run on Sentir, our centralized video management platform optimized for cloud and inter-cloud infrastructure.

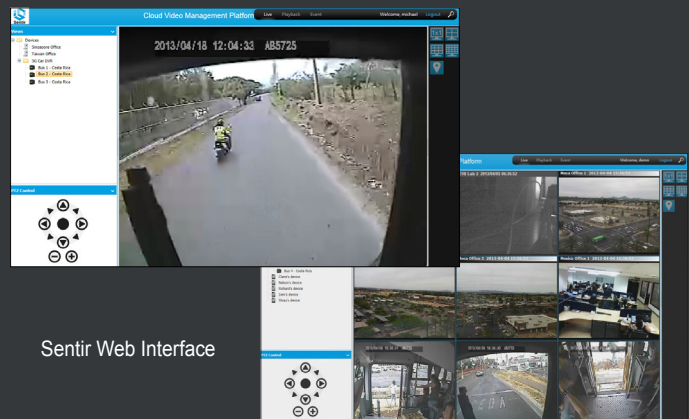

Sentir Web Interface

DuraTech USA Inc.
 A Certified 8(a), SDB, DBE, SBE, MBE, WBE firm.
 Phone: (714) 898-2171 Fax: 866-704-9132
 Email: sales@DuraTechUSA.com www.DuraTechUSA.com

PROTECT LIFE, SUPPORT OFFICERS, IMPROVE OPERATING EFFICIENCIES

In-vehicle video surveillance is increasingly being incorporated into the security solutions of transport operators in the government, commercial, and private sectors. The need for real-time video verification data to increase situational awareness, reducing theft, preventing violence and fraud, as well as improving operating efficiencies are motivating fleet managers and transportation authorities to consider mobile video surveillance systems as a critical part of their business management and security measures. Furthermore, the increased use and deployment of wireless infrastructure are making it easier to integrate real-time video streaming with mobile video surveillance equipment.

VEMO and IvedaOnBoard are our solution to this need. The solution enables our customers with real-time situational assessment of field activities and secured storage of video footage at our secure data centers. This untethered surveillance solution currently utilizes 3G cellular service from select providers.

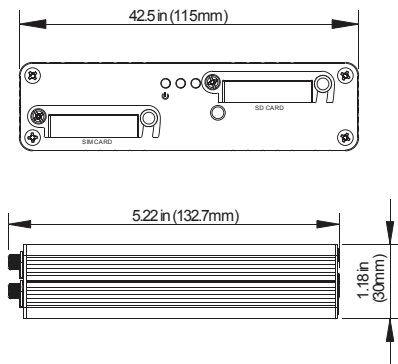

Model: VEMO-2000		4- Channel GPS DVR
Video Input	4CH Input	
Audio Input	1CH Input	
Video Output	1CH output	
Record Resolution	High	D1 720 x 480
	Normal	CIF 360 x 240
Compression Format	H.264Technology	
Recording Mode	Full-time Recording	
Storage	SD Card (not included)	
GPS Position	Included	
Power Supply	DC+12V / 500mA (not including Cameras)	
Dimension	115mm x 132.7mm x 30mm (W x D x H)	
Weight	0.4kg (including SD card)	
Operation Temperature	-20C~ +65C (inside vehicle)	

Model	VEMO-C751R	VEMO-C750
Sensor	1/3" CCD	1/3" CCD
Resolution	420 TV Lines	420 TV Lines
Mounting	Swivel stand with screw mount	Adhesive to Windshield
Power Supply	DC 12 ± 1V	DC 12 ± 1V
Operating Temperature	- 10° C ~ + 60°C	- 10° C ~ + 60°C
Weight	About 170g	About 50g
IR	3M IR range, .1 lux sensitivity	



VEMO-C751R

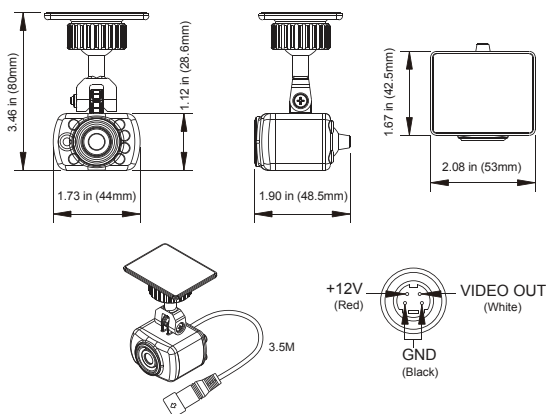

VEMO-C750

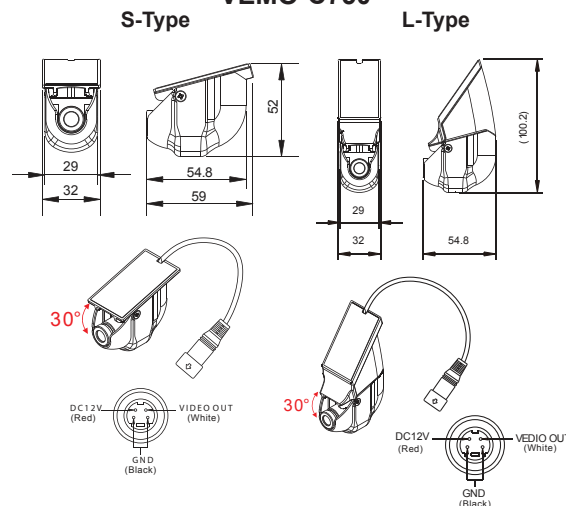

Appropriate Vehicle Types

S-Type



Suitable for slanting windshield of vehicles, eg. Taxi cab, Police car, Van, Sedan, MPV, SUV, SUT, Recreation Vehicle

Van, Sedan, MPV, SUV, SUT, Recreation Vehicle

L-Type



Suitable for upright windshield of vehicles, eg. Truck, Bus, Pickup, Trailer