

Quick Start Guide

Congratulations and thank you for purchasing the computer. This guide provides step-by-step instructions for a quick setup of your computer.

1 Install the battery pack

Install the battery pack if it has not been installed in your computer.

- ▶ Locate the battery compartment on the right side of the computer. Open the compartment cover by pressing on both sides of the release latch using your thumb and index fingers.

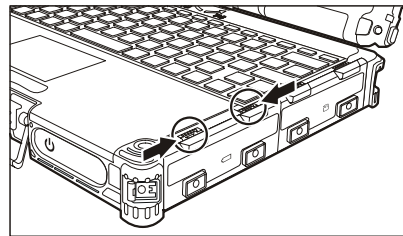

- ▶ Slide the battery pack all the way into the slot. Make sure to observe the correct orientation (the ribbon strip must face outward for future battery back removal).

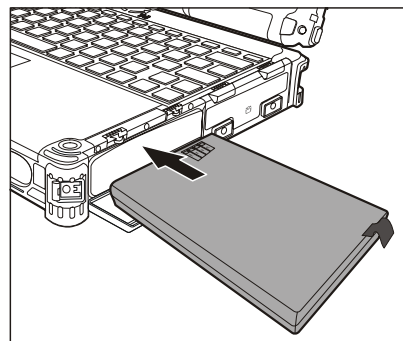

- ▶ Close the compartment cover to secure the battery pack.

2 Connect AC power

The first time you use your computer, use the AC adapter. This will allow the battery pack to fully charge.

- ▶ Plug the DC cord of the AC adapter to the power connector on the computer.
- ▶ Plug the female end of the AC power cord to the AC adapter and the male end to an electrical outlet.

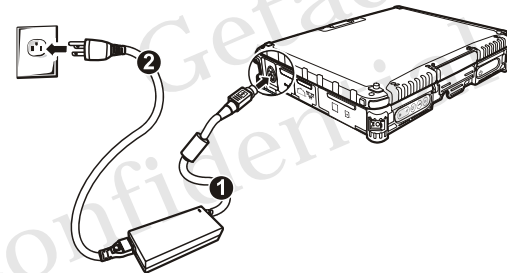

The Battery Charge Indicator (🔋) on the computer glows yellow to indicate that charging is in progress.

3 Power up

- ▶ Open the top cover by pulling up on latch A and releasing latch B (1) and lifting up the cover (2). You can tilt the cover forward or backward for optimal viewing clarity.

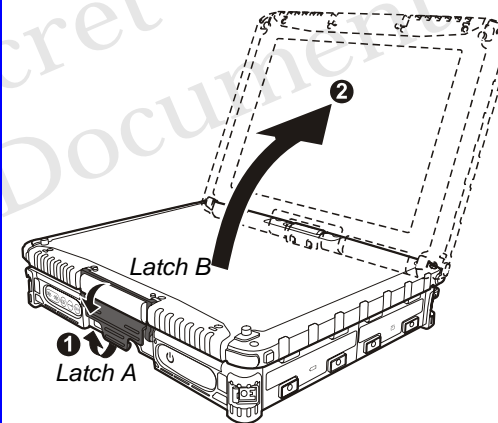

- ▶ Press the power button (🔌) to power up. The operating system such as Windows should start.

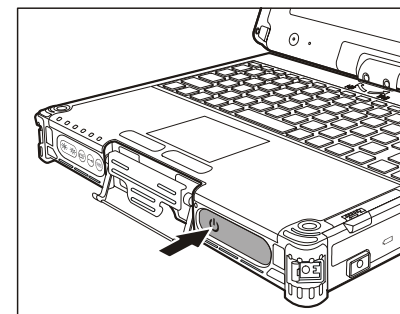

4 Find more information

For complete information, please refer to the User's Manual (in PDF format) supplied on the driver disc.

- ▶ Connect a DVD drive (option) to your computer. Press the eject button of the DVD drive. Fit the driver disc in the tray with its label facing up. Then, press the eject button or manually slide the tray back into place.
- ▶ When the main screen appears, click **Adobe Reader** to install the software for opening the PDF manual file. Then, click **User Guide** to view.



