

WHY SETTLE FOR GENERIC HARDWARE?

All of our computer products can be customized to meet your exact needs and specifications, ranging from custom keypad graphics to highly customized cabling and everything in between. A full range of peripherals and software support services are available through our GEMPASS program, specifically for our GEM Partners.

CUSTOM CASE COLORS



CUSTOM KEYPADS



CUSTOM LOGO TAGS



CUSTOM DISPLAY AND KEYPAD BEZELS

Color and Graphics

Contact us today to learn more about customization options.

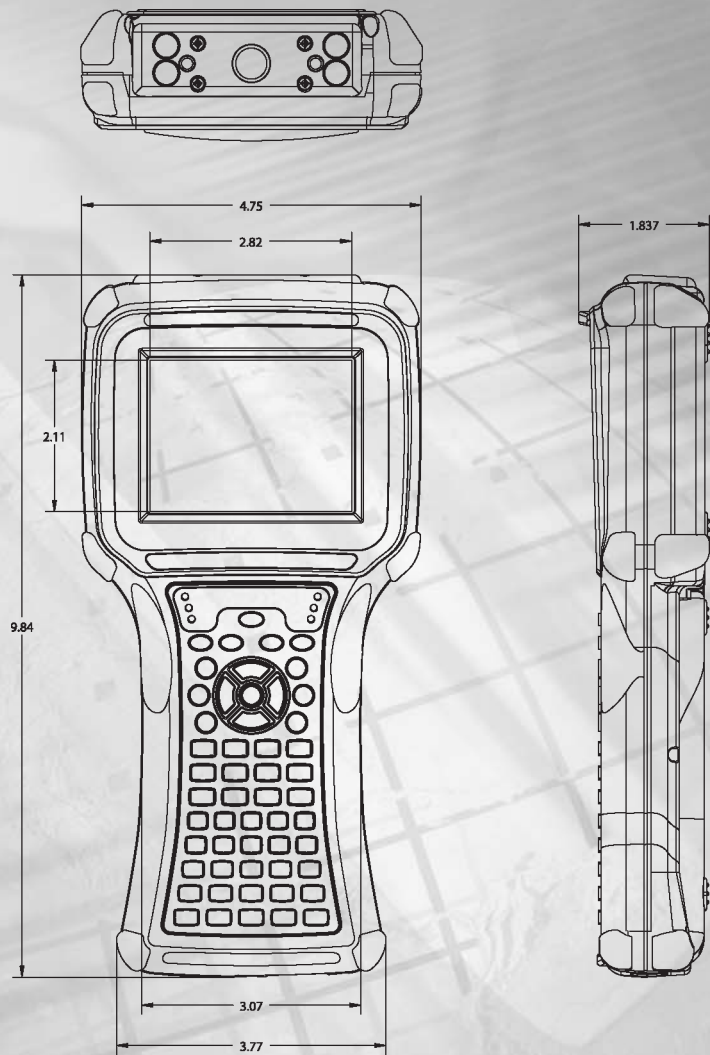

DIMENSIONS

Height: 9.84 inches (249.935 mm)

Width (Display area): 4.75 inches (120.6 mm)

Width (Keypad area): 3.07 inches (78 mm)

Depth: 1.837 inches (46.65 mm)

Display Size (Active area): 2.82 x 2.11 inches (71.6 mm x 53.5 mm)

Weight w/Rechargeable Battery: 32.32 ounces (916.25 Grams)

Weight w/o Battery: 25.6 ounces (725.75 Grams)



Two Technologies, Inc.®

Hand Held Computers • Your Way • Since 1987



jett-eye™

Picturing Your Applications
in a Brand New Light



DuraTech USA, Inc. • 12792 Valley View Street Suite 214 Garden Grove, CA 92845
phone: (714) 898-2171 • fax: (714) 898-2502 • Email: sales@DuraTechUSA.com www.DuraTechUSA.com



Introducing the industry's first fully featured, rugged and customizable hand held computer integrated with a color camera, bar code imager, and wireless connectivity.



When is a picture worth more than a thousand words? When it gives you a differentiated advantage.

Imagine New Possibilities.

Take digital color pictures in the field. Capture data on the go. Seamlessly connect with the office. Simultaneously increase field service productivity, improve customer service, and turbo charge your profits—all while improving your customer relationships. This complex scenario is now made simple with the JETT•eye. It was designed to make all of this possible at an affordable price point.

With integrated Bluetooth® and WLAN 802.11b/g, and a 5 MP color camera system that accomplishes both digital image capture and bar code capture, the JETT•eye streamlines operations and simplifies workflow. Plus, with the IP65 rating, your application is now equipped to survive even the toughest environments.

Customize Your JETT•eye from Top to Bottom.

If you are an OEM, compress your customers' training time with an application-specific keypad. Incorporate your company colors and logo, and put your brand in front of your customers, where it matters most.

If you are a VAR or Systems Integrator, you can differentiate your company by providing your customers with a branded solution. We can customize their case color, keypad, graphics, bumpers, logo tags, serial tags and cabling. Everyone profits. You win their business; they get customized hardware at off-the-shelf prices. Easier, faster, and more affordable than you can imagine.

What Makes Us Different?

Only one company can consistently deliver this kind of affordable customization. Since 1987 Two Technologies has been a leader in the design and manufacturing of innovative, customizable computers for industrial and commercial applications. With second-to-none service and support, you can be assured that we will be there for you every step of the way.

Display

- 320x240 pixel QVGA-TFT color with white LED Backlight • Integrated Touch Screen
- Sunlight readable, unsurpassed image quality

Keys, Switches & Indicators

- NEW 52-key joystick-style keypad standard with bezel nomenclature
- Standard keypads also available:
 - 45-key membrane (10 rows x 4 columns plus 1 x 5 bottom row)
 - 45-key elastomeric (10 rows x 4 columns plus 1 x 5 bottom row)
 - 30-key elastomeric (10 x 3)
 - 15-key elastomeric (5x3)
- Custom layout and graphics (optional)
- Keypad feedback: Tactile and Audible
- LED backlit keypad (optional)
- Power/Resume switch
- LED Indicators
 - 5 programmable
 - One fixed LED for Low Battery/Charge status (battery unit only)
- 8 Definable "Hot" Keys that can be used to execute programs or driver functions

Power

- Nickel Metal Hydride rechargeable batteries (2500 mAh, 7.2V)
- Recharge/Line Power: 11 to 18 VDC, 15 WATT
- 8+ hours average operating time (application dependent)

Environment

- IP65 Ingress Protection
- Storage temperature: -20° to +70°C
- Operating temperature: -20° to +50°C
- Charging temperature: -20° to +40°C
- Humidity: 5-95% (non-condensing)

Custom Options

- Line Powered Unit*
 - Customizable options*: Case Color, Bumper Color, LED Logo Tag (elastomeric keypad only), Keypad Layout (quantity of keys and locations), Keypad Graphics, Bezel Nomenclature, Logo Tag, LED Colors, Serial Tag, Cable and Pin-outs
- *Contact factory

Certifications

- IP65 Ingress Protection (Independent Lab Tested)
- FCC Class A • EN55022, 1998. (CISPR 22) Class A, EN55022/IEC 6100-4-6 RF CONTINUOUS CONDUCTED • EN55024, 1998 - ETSI EN 301489-1,2002 - ETSI EN 301489-3,2002 - EN/IEC 61000-4-2 ESD - EN/IEC 61000-4-3 RF ELECTRO MAGNETIC FIELD - EN/IEC 61000-4-4 FAST TRANSIENTS • EN60950:2000

Software

- Development Environments: Microsoft® eMbedded Visual C++® 4.0, Visual Studio® .NET 2003, Visual Studio® 2005 • 2T Utilities CD: JETT SDK, Developer Tools, Code Samples
- GEMPASS: custom development DLLs, and free development consultation

Peripherals and Accessories

- Desktop and Mobile Battery Chargers
- Desktop Cradles • Latch Mounts
- Carrying cases • Standard and Custom cables
- Pre-Configured 2", 3" and 4" Mobile Thermal Printers and consumables
- RFID+ Read/Write Module (13.56 MHz)
- GPS Integration in JETT•PACK™ (optional)

Optional JETT•PACK™ Peripherals

- PACK Ready • JETT•WAVE Radio • GPS • GPRS • Backup Memory • Mag Stripe Reader
- Customize your solution with the JETT•PACK™ Kit

CPU/Operating System

- Microsoft® Windows® CE 5.0
- OS revision can be frozen upon request
- Intel® PXA270 XScale® Technology Processor - 624MHz

Memory

- 128MB SDRAM (Est. 30MB used for OS)
- System Flash (512MB - 8GB+ available)
- Partitioned for OS storage and application/data storage

Connectivity

Wireless

- Personal Area Network
 - Bluetooth® Class 2 internal
- Local Area Network
 - 802.11b/g internal
- Wide Area Network
 - GPRS or CDMA in JETT•PACK™ (optional)
- Dedicated Area Network
 - JETT•WAVE in JETT•PACK™ (optional)
 - 256 bit encryption available
 - Point to Point, Broadcast, Relay configurations
 - Up to 5 miles range depending upon environment

Wired

- USB v1.1
 - Host and Client Detection on a single On The Go (OTG) Connector
- Asynchronous Serial Ports
 - RS-232, RS-422, RS-485 standards available
- Serial System can be custom configured* as follows:

JETT•eye Serial Configurations*	
JETT•connect	Aux. Connector
RS-232	USB or Charge Jack
Short RS-232 (2)	USB or Charge Jack
Short RS-232 & RS-422	USB or Charge Jack
Short RS-232 & RS-485	USB or Charge Jack
RS-422 & USB	Charge Jack
RS-485 & USB	Charge Jack

NOTE: Short RS-232 = TXD, RXD, CTS, and RTS only. *Some restrictions may apply. Contact Two Technologies for more information.

Rugged True-Camera-System

- 5.17 megapixel color CMOS Sensor
 - 4 megapixel processed
- Image Capture Resolutions
 - QSXGA: 2048 x 1944
 - SXGA: 1280 x 960
 - VGA: 640 x 480
 - HF: 320 x 200
- True-Shutter: A variety of standard shutter speeds up to 1/500 of a second
- True-Focus System
 - Macro 2.25" near focus to infinity far focus
 - eye•WARE Automatic Scene Focus System
 - eye•WARE Automatic Laser Focus System
 - Dual precision aligned red Lasers
 - Software focus system
 - Software measurement system
 - Software selectable manual focus
- Aperture System
 - F 8.0 or F 2.8
 - Software selectable
- High Quality Glass Optics
- IR Coated Lens
- Polarizing Lens (optional)
- True-Light LED Lighting System
 - Programmable Constant On Mode (50,000 hour life)
 - Programmable Flash Mode (400 Lumens output)
- Automatic Exposure System
- Automatic White-Balance System

eye•WARE™ Software Packages

(contact factory for pricing and availability)

eye•SEE™ Software Systems

(contact factory for pricing and latest features)

- Camera Wedge System:
 - eye•SEE-wedge
 - EZ Picture Capture Process Control
 - Intuitive camera interface
 - EZ add-in to existing applications
 - No programming required
- Camera Library System: eye•SEE-DLL
 - Basic, Advanced and Measurement versions
 - Your software control of image capture process
 - .NET and emb C++ development environments

eye•D™ Software Systems

(contact factory for pricing and latest features)

- Bar-Code Symbology Wedge System: eye•D-1
 - 1D bar-code capture (contact factory for symbologies)
 - Customize capture process for your application
 - No programming required
- Camera Library System: eye•D-1-DLL
 - Your software control of 1D symbology capture process
 - Visual Studio® and eMbedded Visual C++® 4.0 development environments

Enhanced Software Options

- Mobile Remote Device Management • Terminal Emulation
- Voice Command Software

GEMPASS

GEMPASS offers a complete menu of resources and technical engineering support in the delivery of customized hand held computer solutions for a variety of industries.

As a GEM Partner, you gain access to the following GEMPASS offerings:

- Mobile Hand Held Technology Experts
- Peripherals/Software Services
- World-class Mobile System Software and Engineering
- Specialized financing options

Become a GEM Partner today and take advantage of these benefits and services: www.2T.com/GEM

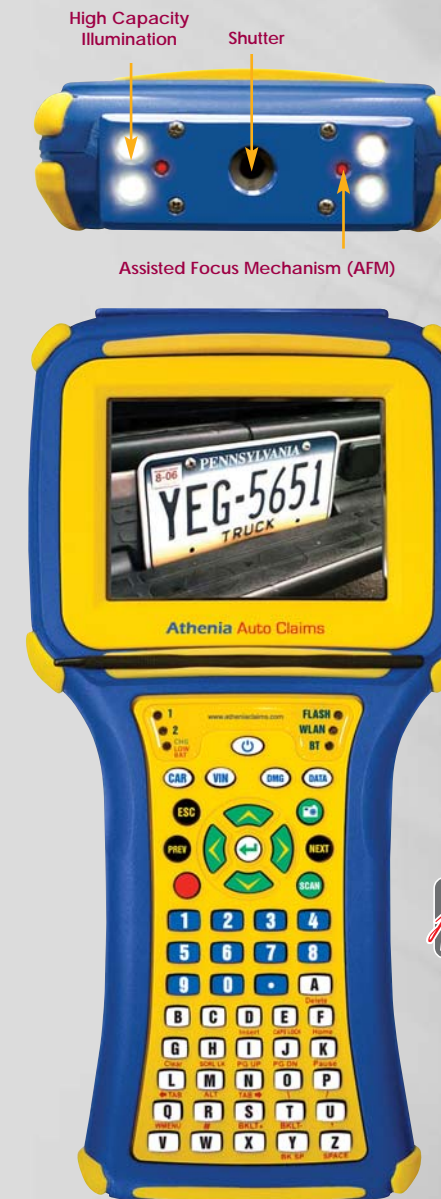

- Display your company name or logo
- Standard and custom case colors available
- Custom keypad layouts and graphics available
- Standard 52-key joystick style keypad shown
- Custom bezel nomenclature available
- Custom wired connectivity options

